

JET

**JDR-34
JDR-34F**

RADIAL DRILL PRESS

10000390M.....230/50/1

10000390T.....400/50/3

10000395M.....230/50/1

10000395T.....400/50/3

PARTS LIST

Walter Meier (Tool) AG

Tämperlistrasse 5

CH-8117 Fällanden

Switzerland

Phone +41 44 806 47 48

Fax +41 44 806 47 58

jetinfo.eu@waltermeier.com

www.jettools.com



P-10000390M/T-10000395M/T 2010-11

Parts Breakdown for JDR-34 and JDR-34F Radial Drill Press

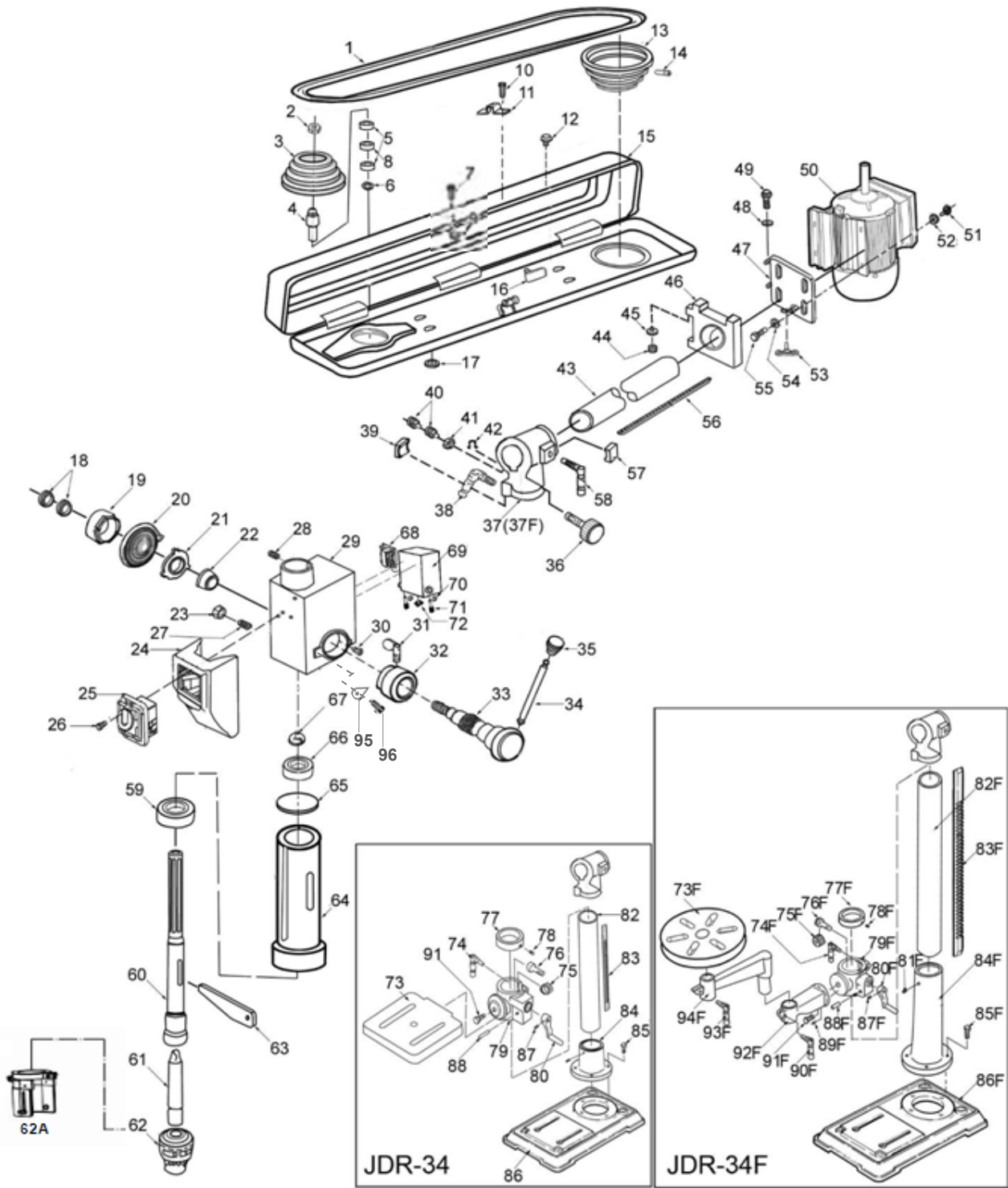

Parts List for JDR-34 and JDR-34F Radial Drill Press

Index	Part No.	Description	Size	Qty.
1	JDR34-001	BELT-"V"	M58	1
2	JDR34-002	PULLEY NUT		1
3	JDR34-003	SPINDLE PULLEY		1
4	JDR34-004	INSERT PULLEY		1
5	JDR34-005	BEARING-BALL	80203	2
6	JDR34-006	RETAINING RING	17MM	1
7	JDR34-007	SCREW	M5X16	1
8	JDR34-008	SPACER 1302023	1302023	1
9	JDR34-009	LOCK NUT	M5	1
10	JDR34-010	SCREW	M5X12	1
11	JDR34-011	CLAMP CORD		1
12	JDR34-012	SCREW	M6X12	1
13	JDR34-013	MOTOR PULLEY		1
14	JDR34-014	SCREW	M6X10	1
15	JDR34-015	BELT GUARD		1
16	JDR34-016	MICRO SWITCH		1
17	JDR34-017	FORM WASHER		4
18	JDR34-018	NUT-HEX	M12	2
19	JDR34-019	CAP-SPRING		1
20	JDR34-020	SPRING-TORSION		1
21	JDR34-021	RETAINER-SPRING		1
22	JDR34-022	SEAT-SPRING		1
23	JDR34-023	NUT-HEX	M8	1
24	JDR34-024	BOX SWITCH		1
25	JDR34-025	MAGNETIC SWITCH 230V		1
	JDR34-025AE	MAGNETIC SWITCH 400V 3Phase		1
26	JDR34-026	TAPPING SCREW	ST4.2X9.5	1
27	JDR34-027	SCREW 1302021		1
28	JDR34-028	SCREW-SOCKET SET		1
29	JDR34-029	HEAD		1
30	JDR34-030	PIN-STOP		1
31	JDR34-031	LOCK-DEPTH SCREW		1
32	JDR34-032	RING-DEPTH STOP		1
33	JDR34-033	HUB		1
34	JDR34-034	FEED-ROD		3
35	JDR34-035	FEED-KNOB		3
36	JDR34-036	MOVING-BAR		1
37	JDR34-037	GUIDE-COLUMN		1
38	JDR34-038	CLAMPING-LEVER		1
39	JDR34-039	LOCKING-SHOE		1
40	JDR34-040	HEX SCREW	M5X6	2
41	JDR34-041	NUT	M16	1
42	JDR34-042	RING-RETAINING		1
43	JDR34-043	HORIZONTAL-TUBE		1
44	JDR34-044	SCREW-HEX	M8X16	1
45	JDR34-045	WASHER	M8	1
46	JDR34-046	MOUNT-COVER		1
47	JDR34-047	MOUNT-MOTOR		1
48	JDR34-048	NUT HEX	M8	1
49	JDR34-049	SCREW-HEX	M8X20	1
50	JDR34-050	MOTOR 230V 50Hz 1Phase		1
	JDR34-050AE	MOTOR 400V 50Hz 3Phase		1
51	JDR34-051	NUT HEX	M8	1
52	JDR34-052	WASHER	M8	1
53	JDR34-053	THUMB NUT		1
54	JDR34-054	WASHER	M8	1
55	JDR34-055	SCREW-HEX	M8X20	1
56	JDR34-056	HORIZONTAL-RACK		1

Parts List for JDR-34 and JDR-34F Radial Drill Press

Index	Part No.	Description	Size	Qty.
57	JDR34-057	LOCKING SHOE		1
58	JDR34-058	CLAMPING-LEVER		1
59	JDR34-059	BEARING-BALL	80204	1
60	JDR34-060	SPINDLE		1
61	JDR34-061	ARBOR		1
62	JDR34-062	CHUCK		1
62A	JDR34-062A	CHUCK GUARD		1
63	JDR34-063	KEY-DRIFT		1
64	JDR34-064	TUBE-QUILL		1
65	JDR34-065	WASHER RUBBER		1
66	JDR34-066	BEARING-BALL	80203	1
67	JDR34-067	RING-RETAINING		1
69	JDR34-069	LASER BOX		1
70	JDR34-070	RETAINING WASHER		2
71	JDR34-071	LASER POINTER		2
72	JDR34-072	LASER ON/OFF SWITCH		1
	JDR34-072A	LASER SWITCH BOX ASSEMBLY (68~72)		
73	JDR34-073	TABLE		1
74	JDR34-074	TABLE CLAMP		1
75	JDR34-075	GEAR-HELICAL		1
76	JDR34-076	WORM-ELEVATION		1
77	JDR34-077	COLUMN COLLAR		1
78	JDR34-078	SCREW	M6X10	1
79	JDR34-079	TABLE SUPPORT		1
80	JDR34-080	CRANK		1
82	JDR34-082	COLUMN		1
83	JDR34-083	RACK		1
84	JDR34-084	COLUMN SUPPORT		1
85	JDR34-085	HEX BOLT	M8X20	4
86	JDR34-086	BASE		1
87	JDR34-087	SCREW	M6X10	1
88	JDR34-088	PIN GEAR		1
91	JDR34-091	HEX BOLT	M12X22	1
73F	JDR34-073F	TABLE		1
74F	JDR34-074F	SUPPORT CLAMP		1
75F	JDR34-075F	GEAR-HELICAL		1
76F	JDR34-076F	WORM-ELEVATION		1
77F	JDR34-077F	COLUMN COLLAR		1
78F	JDR34-078F	SCREW	M6X10	1
79F	JDR34-079F	TABLE SUPPORT		1
80F	JDR34-080F	CRANK		1
81F	JDR34-081F	SCREW	M10X12	1
82F	JDR34-082F	COLUMN		1
83F	JDR34-083F	RACK		1
84F	JDR34-084F	COLUMN SUPPORT		1
85F	JDR34-085F	HEX BOLT	M10X40	4
86F	JDR34-086F	BASE		1
87F	JDR34-087F	SCREW	M6X10	1
88F	JDR34-088F	PIN GEAR		1
89F	JDR34-089F	SCREW	M6X10	1
90F	JDR34-090F	TABLE CLAMP		1

Parts List for JDR-34 and JDR-34F Radial Drill Press

Index	Part No.	Description	Size	Qty.
91F	JDR34-091F	HEX BOLT	M16X35	1
92F	JDR34-092F	ARM		1
93F	JDR34-093F	TABLE CLAMP		1
94F	JDR34-094F	EXTEND ARM		1
95	JDR34-095	DEPTH GAUGE PLATE		1
96	JDR34-096	SCREW	M4x8	1

Wiring Diagram JDR-34 and JDR-34F Radial Drill Press

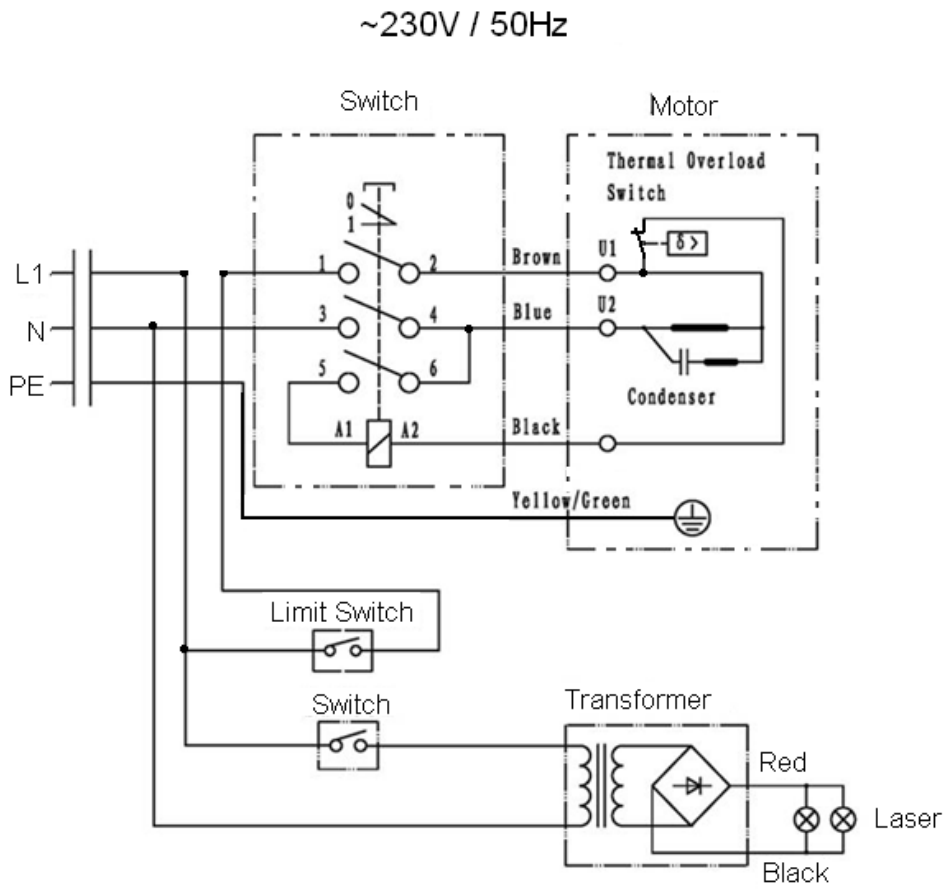

Wiring Diagram JDR-34 and JDR-34F Radial Drill Press

3~400V / 50Hz

