

# JET

**MBG-75**

**MBG-75DC**

**MBG-150**

**MBG-150DC**

**METAL BELT GRINDER**

**50000370T**

**50000371T**

**50000372T**

**50000373T**

**400/50/3**

## PARTS LIST

**Walter Meier (Tool) AG**

Tämperlistrasse 5

Ch-8117 Fällanden

Switzerland

Phone +41 44 806 47 48

Fax +41 44 806 47 58

[jetinfo.eu@waltermeier.com](mailto:jetinfo.eu@waltermeier.com)

[www.jettools.com](http://www.jettools.com)



P50000370T 2010/06/25

# Parts Breakdown for MBG-75 and MBG-150

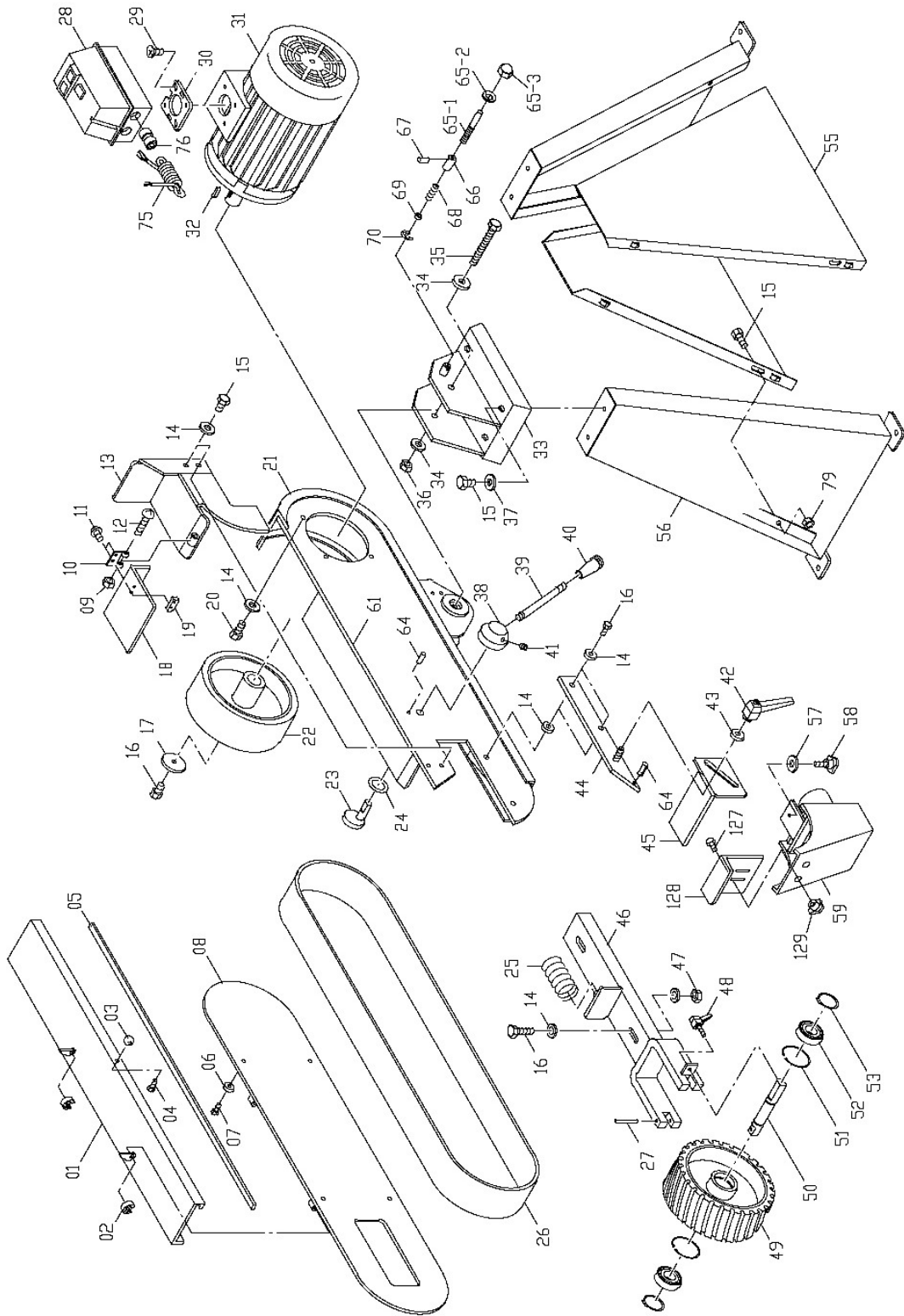

## Parts List for the MBG-75 and MBG-150

Index	Part	Description	Size	Qty.
1	MBG75-01	Upper Cover		1
	MBG150-01	Upper Cover		1
2	MBG75-02	Ring	E6	2
3	MBG75-03	Ball Handle	1/4"xDia.22	1
4	TS-0050011	Hex Head Bolt	1/4"x1/2"	1
5	MBG75-05	Rubber		1
6	TS-1550041	Flat Washer	M6	4
7	TS-1482031	Hex Head Bolt	M6x16	4
8	MBG75-08	Cover		1
9	TS-1540041	Hex Nut	M6	1
10	MBG75-10	Hinge		1
11	TS-1532032	Pan Head Screw	M4x10	11
12	MBG75-12	Pan Head Screw	M6x45	1
13	MBG75-13	Stop Plate		1
	MBG150-13	Stop Plate		1
14	TS-1550061	Flat Washer	M8	16
15	TS-1490021	Hex Head Bolt	M8x16	14
16	TS-1490041	Hex Head Bolt	M8x25	5
17	TS-1550061	Flat Washer	M8	1
18	MBG75-18	Eye Shield		1
	MBG150-18	Eye Shield		1
19	MBG75-19	Set Plate		1
20	TS-1504051	Socket Head Cup Screw	M8x25	4
21	MBG75-21	Frame		1
	MBG150-21	Frame		1
22	MBG75-22	Rubber Wheel		1
	MBG150-22	Rubber Wheel		1
23	MBG75-23	Eccentric Cam		1
24	MBG75-24	Washer	Dia.15	1
25	MBG75-25	Spring		1
26	MBG75-26	Sanding Belt	75x2000, 60 Grit	1
	MBG150-26	Sanding Belt	150x2000, 60 Grit	1
27	MBG75-27	Pin	M6x50	1
28	MBG75-28	Magnetic Switch		1
29	MBG75-29	Pan Head Screw	3/16"x1/2"	4
30	MBG75-30	Rubber Pad		1
31	MBG75-31	Motor	5HP,3Ph,400V	1
32	MBG75-32	Key	8x7x35	1
33	MBG75-33	Stand Upper Cover		1
34	TS-2360121	Flat Washer	M12	1
35	TS-1492101	Hex Cap Screw	M12x100	1
36	TS-2341121	Hex Nut – Nylon Lock	M12	1
37	TS-1550061	Flat Washer	M8	24
38	MBG75-38	Handle Base		1
39	MBG75-39	Handle Bar		1
40	MBG75-40	Handle		1
41	TS-1524011	Socket Set Screw	M8x8	2
42	MBG75-42	Adjustable Handle	M10	1
43	TS-1550071	Flat Washer	M10	1
44	MBG75-44	Tool Rest Support		1
45	MBG75-45	Tool Rest		1
	MBG150-45	Tool Rest		1
46	MBG75-46	Wheel Support		1
	MBG150-46	Wheel Support		1
47	TS-1541031	Hex Nut – Nylon Lock	M8	2
48	MBG75-48	Adjustable Handle	M6x15	1

49	MBG75-49	Gear Type Rubber Wheel		1
	MBG150-49	Gear Type Rubber Wheel		1
50	MBG75-50	Shaft		1
	MBG150-50	Shaft		1
51	MBG75-51	Ring	R42	2
52	BB-6004VV	Ball Bearing	6004LLU	2
53	MBG75-53	Ring	S20	2
55	MBG75-55	Stand Plate(L+R)		2
56	MBG75-56	Stand Plate(F+R)		2
57	TS-1550041	Flat Washer	M6	1
58	MBG75-58	Knob	M6x14	1
59	MBG75-59	Dust Tray		1
	MBG150-59	Dust Tray		1
61	MBG75-61	Graphite Cloth	75x495	1
	MBG150-61	Graphite Cloth	150x495	1
64	MBG75-64	Pin	M6x15	1
65-1	MBG75-65-1	Set Pin		1
65-2	MBG75-65-2	Knob	M6	1
65-3	MBG75-65-3	Round Cap Nut	M6	1
66	MBG75-66	Collar		1
67	MBG75-67	Pin		1
68	MBG75-68	Spring		1
69	MBG75-69	Washer		1
70	MBG75-70	Ring	E4	1
75	MBG75-75	Power Cord	H07RN-F 1.0mm <sup>2</sup> 4G	1
76	MBG75-76	Cable Clamp		1
79	TS-1540061	Hex Nut	M8	4
127	TS-1482011	Hex Cap Screw	M6x10	1
128	MBG75-128	Guard		1
129	MBG75-129	Knob		1

# Parts Breakdown for MBG-75DC and MBG-150DC

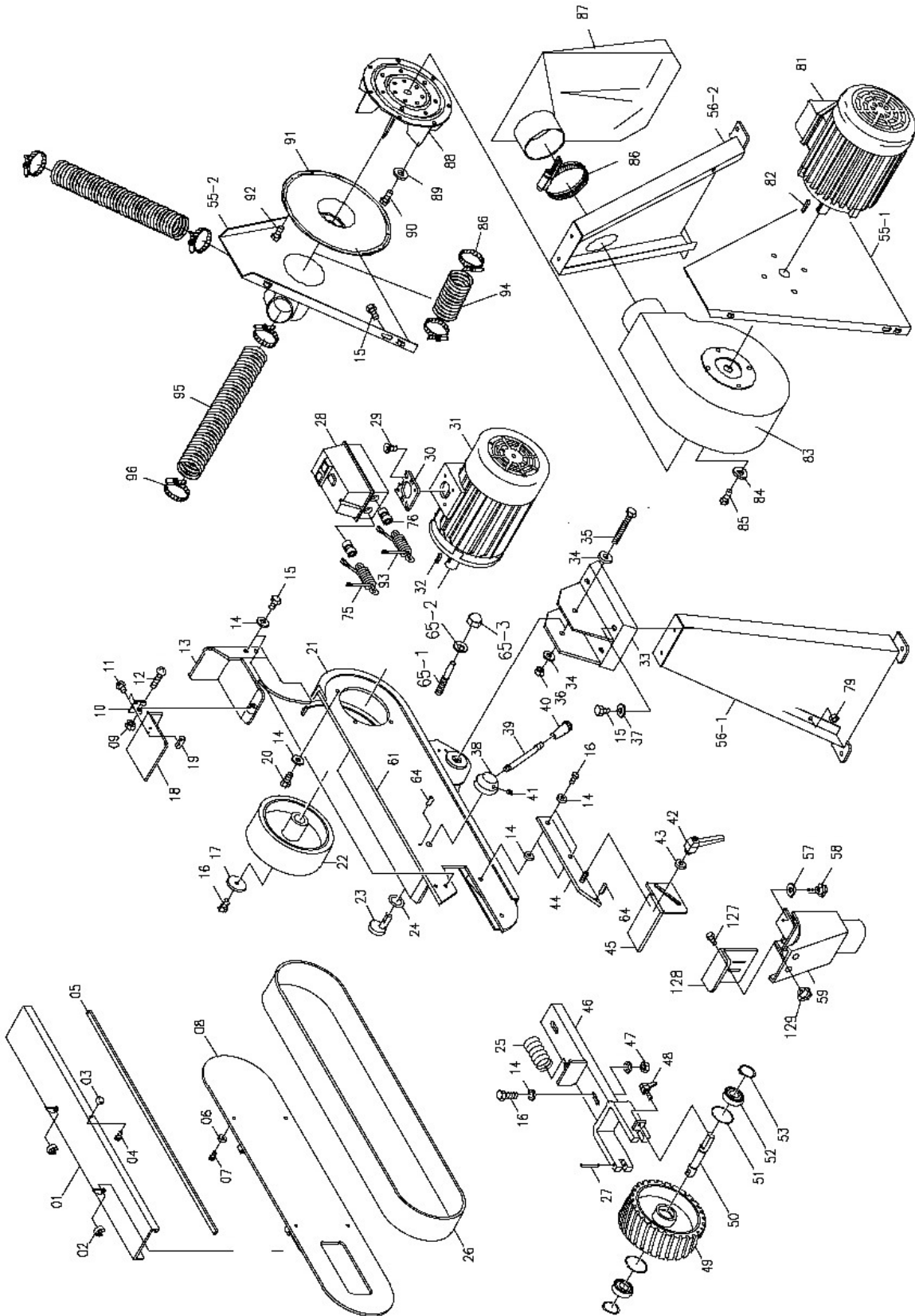

## Parts List for the MBG-75DC and MBG-150DC

Index	Part	Description	Size	Qty.
1	MBG75-01	Upper Cover		1
	MBG150-01	Upper Cover		1
2	MBG75-02	Ring	E6	2
3	MBG75-03	Ball Handle	1/4"xDia.22	1
4	TS-0050011	Hex Head Bolt	1/4"x1/2"	1
5	MBG75-05	Rubber		1
6	TS-1550041	Flat Washer	M6	4
7	TS-1482031	Hex Head Bolt	M6x16	4
8	MBG75-08	Cover		1
9	TS-1540041	Hex Nut	M6	1
10	MBG75-10	Hinge		1
11	TS-1532032	Pan Head Screw	M4x10	11
12	MBG75-12	Pan Head Screw	M6x45	1
13	MBG75-13	Stop Plate		1
	MBG150-13	Stop Plate		1
14	TS-1550061	Flat Washer	M8	16
15	TS-1490021	Hex Head Bolt	M8x16	14
16	TS-1490031	Hex Head Bolt	M8x20	5
17	TS-1550061	Flat Washer	M8	1
18	MBG75-18	Eye Shield		1
	MBG150-18	Eye Shield		1
19	MBG75-19	Set Plate		1
20	TS-1504051	Socket Head Cup Screw	M8x25	4
21	MBG75DC-21	Frame		1
	MBG150-21	Frame		1
22	MBG75-22	Rubber Wheel		1
	MBG150-22	Rubber Wheel		1
23	MBG75-23	Eccentric Cam		1
24	MBG75-24	Washer	Dia.15	1
25	MBG75-25	Spring		1
26	MBG75-26	Sanding Belt	75x2000, 60 Grit	1
	MBG150-26	Sanding Belt	150x2000, 60 Grit	1
27	MBG75-27	Pin	M6x50	1
28	MBG75DC-28	Magnetic Switch		1
29	MBG75-29	Pan Head Screw	3/16"x1/2"	4
30	MBG75-30	Rubber Pad		1
31	MBG75-31	Motor	5HP,3Ph,400V	1
32	MBG75-32	Key	8x7x35	1
33	MBG75-33	Stand Upper Cover		1
34	TS-2360121	Flat Washer	M12	1
35	TS-1492101	Hex Cap Screw	M12x100	1
36	TS-2341121	Hex Nut - Nylon Lock	M12	1
37	TS-1550061	Flat Washer	M8	24
38	MBG75-38	Handle Base		1
39	MBG75-39	Handle Bar		1
40	MBG75-40	Handle		1
41	TS-1524011	Socket Set Screw	M8x8	2
42	MBG75-42	Adjustable Handle	M10	1
43	TS-1550071	Flat Washer	M10	1
44	MBG75-44	Tool Rest Support		1
45	MBG75-45	Tool Rest		1
	MBG150-45	Tool Rest		1
46	MBG75-46	Wheel Support		1
	MBG150-46	Wheel Support		1
47	TS-1541031	Hex Nut - Nylon Lock	M8	2

48	MBG75-48	Adjustable Handle	M6x15	1
49	MBG75-49	Gear Type Rubber Wheel		1
	MBG150-49	Gear Type Rubber Wheel		1
50	MBG75-50	Shaft		1
	MBG150-50	Shaft		1
51	MBG75-51	Ring	R42	2
52	BB-6004VV	Ball Bearing	6004LLU	2
53	MBG75-53	Ring	S20	2
55-1	MBG75DC-55-1	Right Side Stand Plate		1
55-2	MBG75DC-55-2	Left Side Stand Plate		1
56-1	MBG75-56	Front Side Stand Plate		1
56-2	MBG75DC-56-2	Rear Side Stand Plate		1
57	TS-1550041	Flat Washer	M6	1
58	MBG75-58	Knob	M6x14	1
59	MBG75DC-59	Dust Tray		1
	MBG150-59	Dust Tray		1
61	MBG75-61	Graphite Cloth	75x495	1
	MBG150-61	Graphite Cloth	150x495	1
64	MBG75-64	Pin	M6x15	1
65-1	MBG75-65-1	Set Pin		1
65-2	MBG75-65-2	Knob	M6	1
65-3	MBG75-65-3	Round Cap Nut	M6	1
66	MBG75-66	Collar		1
67	MBG75-67	Pin		1
68	MBG75-68	Spring		1
69	MBG75-69	Washer		1
70	MBG75-70	Ring	E4	1
75	MBG75-75	Power Cord	H07RN-F 1.0mm <sup>2</sup> 4G	1
76	MBG75-76	Cable Clamp		2
79	TS-1540061	Hex Nut	M8	4
81	MBG75DC-81	Motor	1/2HP,3Ph,400V	1
82	MBG75DC-82	Key	5x5x20	1
83	MBG75DC-83	Fan Housing		1
84	TS-1550041	Flat Washer	M6	4
85	TS-0010061	Hex Cap Screw	1/4"x1-1/4"	4
86	JW1022	Hose Clamp	Dia.4"	3
87	MBG75DC-87	Dust Bag		1
88	MBG75DC-88	Impeller	Dia.9"	1
89	TS-1550041	Flat Washer	M6	1
90	TS-1482031	Hex Cap Screw	M6x16	1
91	MBG75DC-91	Cover		1
92	TS-1534041	Pan Head Screw	M5x10	12
93	MBG75DC-93	Motor Cord	H05VV-F 1.0mm <sup>2</sup> 4G	1
94	MBG75DC-94	Flex Hose	Dia.4"	1
95	MBG75DC-95	Hose	Dia.3"	2
96	JW1021	Hose Clamp	Dia.3"	4
127	TS-1482011	Hex Cap Screw	M6x10	1
128	MBG75-128	Guard		1
129	MBG75-129	Knob		1

# MBG-75 / MBG-150

50000370T / 50000372T

	colour of strands	Litzenfarben	couleur des cordons
BK	black	schwarz	noir
WH	white	weiß	blanc
BU	blue	blau	bleu
YE	yellow	gelb	jaune
RD	red	rot	rouge
BN	brown	braun	brun
GY	grey	grau	gris
GNYE	green-yellow	grün-gelb	vert-jaune
OG	orange	orange	orange
VT	violet	violett	violet

	meaning of symbol	Bedeutung der Zeichen	interprétation
M	motor	Motor	moteur
S	switch	Schalter	interrupteur
C	condenser	Kondensator	condensateur
E	electronic unit	Elektronik Einheit	unité électronique
F	fuse	Sicherung	fusible
RS	reversing switch	Drehrichtungsschalter	commu. droite/gauche
CS	centrifugal switch	Fliehkraftschalter	déclencheur centrifuge
OL	overload cut-off	Überlastschuttschalter	déclencheur surcharge
LS	limit switch	Positionsendschalter	micro

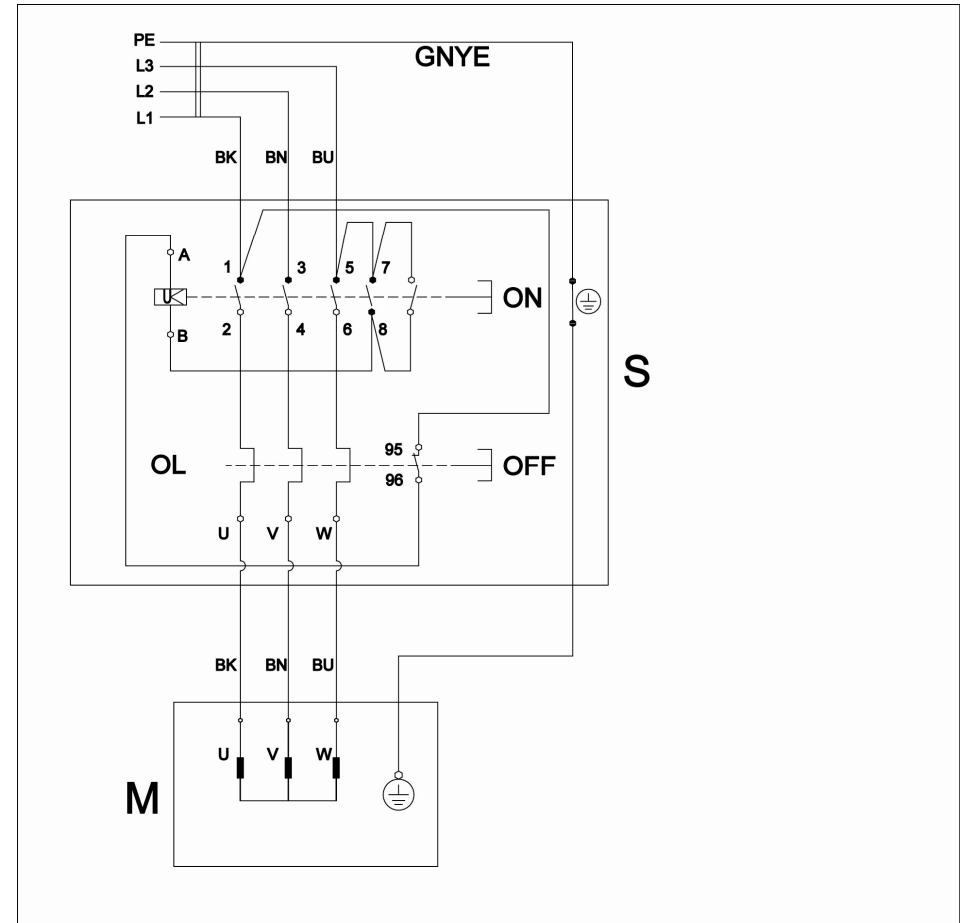



# MBG-75DC / MBG-150DC

50000371T / 50000373T

	colour of strands	Litzenfarben	couleur des cordons
BK	black	schwarz	noir
WH	white	weiß	blanc
BU	blue	blau	bleu
YE	yellow	gelb	jaune
RD	red	rot	rouge
BN	brown	braun	brun
GY	grey	grau	gris
GNYE	green-yellow	grün-gelb	vert-jaune
OG	orange	orange	orange
VT	violet	violett	violet

	meaning of symbol	Bedeutung der Zeichen	interprétation
M	motor	Motor	moteur
S	switch	Schalter	interrupteur
C	condenser	Kondensator	condensateur
E	electronic unit	Elektronik Einheit	unité électronique
F	fuse	Sicherung	fusible
RS	reversing switch	Drehrichtungsschalter	commu. droite/gauche
CS	centrifugal switch	Fliehkraftschalter	déclencheur centrifuge
OL	overload cut-off	Überlastschuttschalter	déclencheur surcharge
LS	limit switch	Positionsendschalter	micro

